

Electrical Connection

(For Current Range Models following 04.15.2010)

☛ Connection:

- The “120” in the “120/240 V” (Fig. 28) indicates an internal wiring circuit between the L2 and N terminals that powers the spark ignition system only. The range must have 208-240v supplied to the terminal block electrical connection even on “All Gas” ranges.
- Use a 4-wire cord rated for 30A 125 / 250 VAC, type SRD, SRDT, S, SO or ST (Or NEMA 14-30P) for ranges up to 6,240W total Wattage.
- Use a 4-wire cord rated for 50A 125 / 250 VAC, type SRD, SRDT, S, SO or ST (Or NEMA 14-50P) for ranges above 6,240W total Wattage.
- Where local Codes do not permit grounding through neutral, use a 4-wire power supply cord or “pigtail” kit. Cord must be agency approved for use with household ranges.
- Remove access door **O** (Figure 25, all gas oven range) or **P** (Figure 26, gas and electric range).
- Feed cord through rubber grommet after cutting an X in the center of grommet, item **Q** (Figure 27).
- Connect to terminal block in accordance with figure 28.
- Make sure jumper bars are secured between terminals 1, 2 and 4, 5 (as shown in Figure 27 & 28). Leave No Loose Terminal Screws or Connections.
- Refit access door

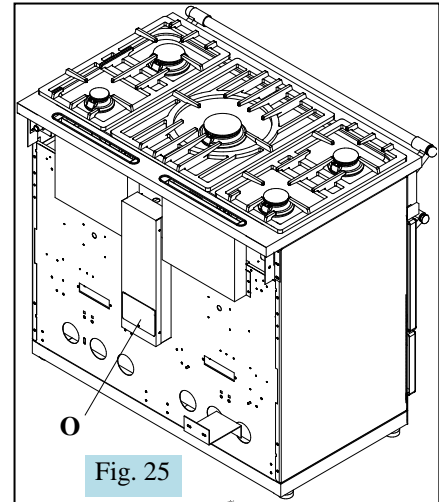

Fig. 25

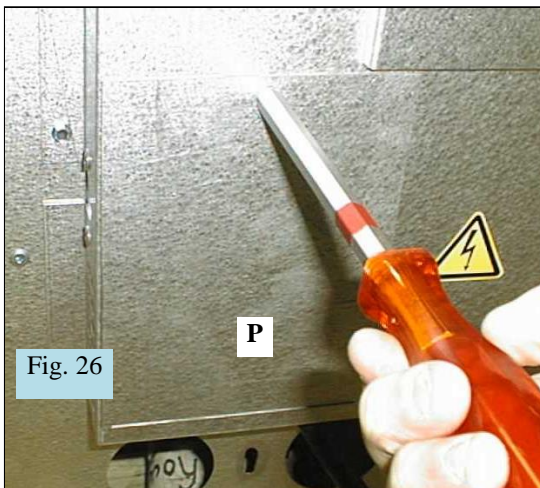

Fig. 26

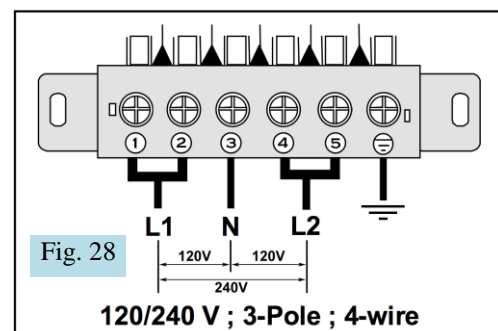
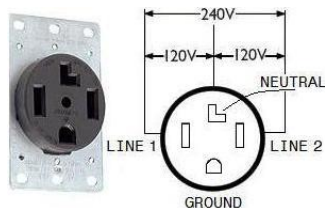
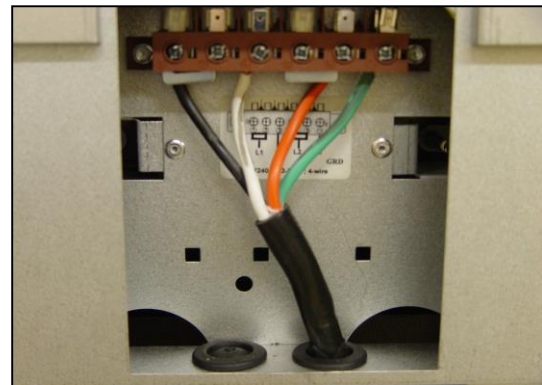

Fig. 28

120/240 V ; 3-Pole ; 4-wire

To see a video of these instructions, please refer to:

<http://www.frenchranges.com/support/video/current/electrical-connection.mp4>