

« *LACANCHE* »

USER'S MANUAL

IMPORTANT

Provide adequate air supply during use of the appliance.

Provide adequate clearances for servicing and proper operation by not obstructing front or side of appliances.

WARRANTY

**The warranty is stated on the sales contract.
Please contact your approved Dealer if any work has to be carried out under warranty.
This warranty excludes damage resulting from incorrect installation, improper use or inadequate servicing.**



SAFETY INSTRUCTIONS

- **If the range is to be installed on an area covered with linoleum or any other floor covering, make sure that the floor covering can withstand 90 F (65°C) above room temperature without warping, shrinking or discoloring. Do not install the range over carpeting.**
- **Never store anything in the oven or the cooktop. Flammable materials can catch fire, plastic items may melt or ignite and other types of items could be ruined.**
- **This appliance is for cooking. Based on safety considerations, never use the oven or cooktop to warm or heat a room. Also, such use can damage the cooktop or oven parts.**
- **Do not obstruct the flow of combustion or ventilation air to the appliance. Be sure a fresh air supply is available.**
- **When using the cooktop, do not touch the burner grates or the immediate surrounding area. Areas adjacent to the burners may become hot enough to cause burns.**
- **Do not hang articles from any part of the appliance or place anything against the oven. Some fabrics are quite flammable and may catch on fire.**
- **However, children should not be left alone in the kitchen while the range is in use. Do not store items of interest to children over the unit. Children climbing to reach items could be seriously injured.**
- **Do not use aluminum foil to line any part of the oven or cooktop.**
- **When using the oven, do not touch the interior surfaces of the oven, the exterior area immediately surrounding the door or the backtrim.**
- **Disconnect from power supply before servicing.**



USER'S MANUAL VOUGEOT - VOLNAY

GAS SURFACE BURNERS

Highly valued by chefs because of their fast heating and ease of use, gas flame burners have always been traditional heat sources for cooking in large kitchens. Other heat sources have appeared in recent years but just as many users still prefer gas. It offers many advantages; gas provides a fast increase in temperature. The height of the flame can be checked easily at a glance in order to increase or reduce its power.

Lacanche gas hobs for cook's stoves are fitted with burners of different ratings. These automatically stabilised flame burners offer a very low slow setting to facilitate simmering or high heat for quick sealing. Depending on their rating, they are suitable for various types of utensils.

Semi fast burner : is recommended for small sauceboats, small saucepans or blinis pans for example. A reducing adapter can be placed on the pan support in order to obtain greater stability (§ accessories)

Fast and intensive burners : are ideal for shallow frying pans, saucepans and cooking pots. Their high output provides very fast increases in temperature and very flexible use.

Ultra fast burner : is a high-power burner. It is especially recommended when using large utensils up to 40 cm in diameter for slow cooked dishes (pot au feu, cassoulet, jams, etc.) or dishes that have to be sealed quickly (fricassees, fritters, grilled meat).

You will quickly learn how to use the various types of burners to achieve optimum cooking.

Description :

The burners are arranged on a stainless steel hob in various configurations depending on the model. Each burner is equipped with electric ignition.

The various types of burners can be identified by their respective diameter.

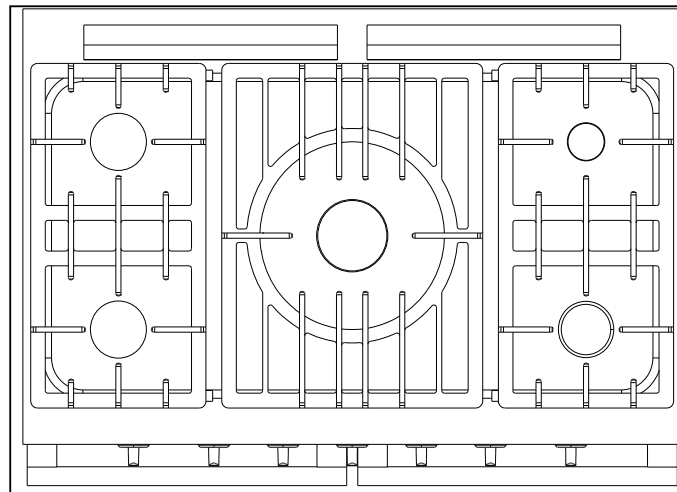

Designation	Burner diameter
Ultra fast	Ø 107 mm
Intensive	Ø 90 mm
Fast	Ø 72 mm
Semi fast	Ø 55 mm



USER'S MANUAL VOUGEOT - VOLNAY

Use :

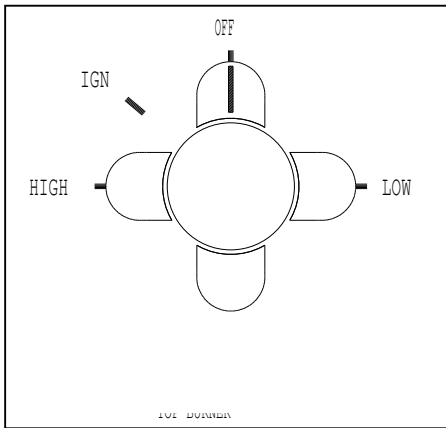

Turn gas supply on.

Rotate burner valve handle to lighting position “IGN”.

Depress handle and turn burner valve handle to full position to shut down burner.

Rotate burner valve handle to off position.

A reduced flowrate position identified by the “LOW” mark produces the preset minimum burner power.

Useful hint :

Always choose a burner that matches the diameter of the utensil used.

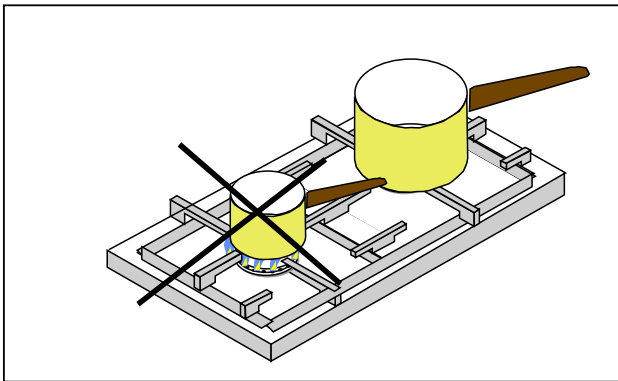

CAUTION:

During use of the cooking surface or oven, accessible parts may become very hot during use. Warn users of the potential hazards.

Cleaning :

**CLOSE THE MAINS GAS VALVE
BEFORE CLEANING**

The burners are made in two parts in order to facilitate cleaning. Clean them separately.

After removing the pan supports and burners, the cooking surface can be cleaned easily and thoroughly by simply using a sponge.

Do not use scouring pads or abrasive products such as oven cleaners and stain removers.

When cleaning, be careful not to splash liquid into the openings of the burners.



USER'S MANUAL VOUGEOT - VOLNAY

HEATING PLATE

**DANGER: Temperature may exceed 300 °C.
Warn potential users of hazards involved.**

The heating plate is a cast iron plate heated by a high-power gas burner. It can be used as a work surface and several saucepans can be placed on it at the same time.

Cast iron stores and retains heat uniformly over its entire surface and it is possible to cook or simmer dishes depending on the temperature. Using the heating plate is ideal for cooking a pot au feu, coq au vin, warming a veal or fish stock or even binding a sauce.

By removing the central plug of the plate, the burner can be used as a traditional flame burner. “**TRADITION**” type gas hobs are equipped with a heating plate.

Description :

The heating plate is made entirely of cast iron. It consists of two parts, the main part rests directly on the cooking surface and the other removable plug part is located in the middle of the plate.

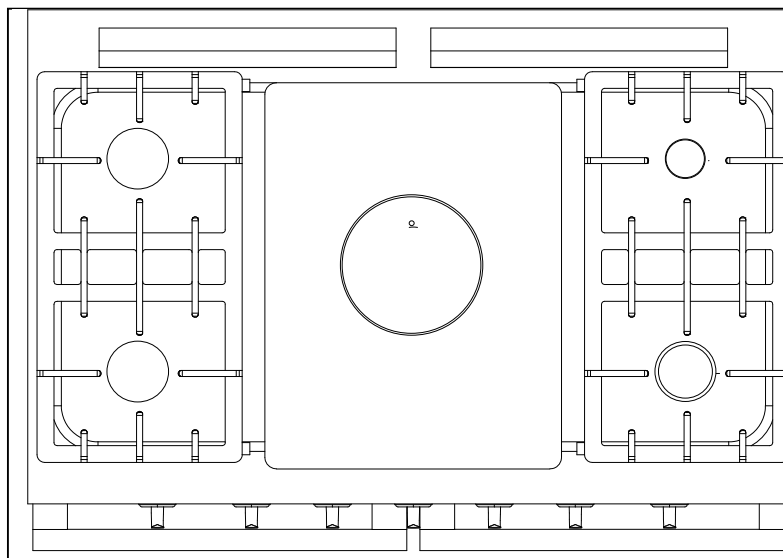



USER'S MANUAL VOUGEOT - VOLNAY

Use :

 Before using your heating plate for the first time, it is advisable to pre-heat the heating plate with the burner set to the low flame position. When the plate is sufficiently hot, turn off the burner and then grease the plate by using a cloth soaked in vegetable oil (e.g. ground-nut oil). Once this operation has been performed 3 or 4 times the cast iron will be protected against oxidation.

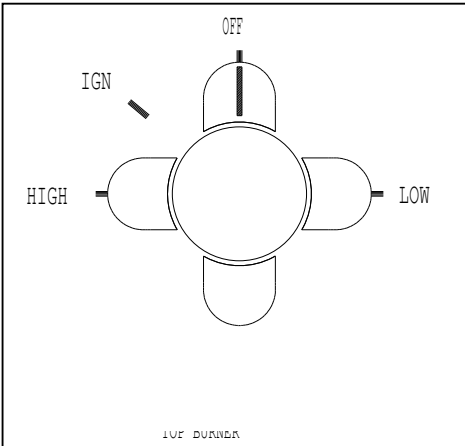

Turn gas supply on.

Rotate burner valve handle to lighting position “**IGN**”.

Depress handle and turn burner valve handle to full position to shut down burner.

Rotate burner valve handle to “**OFF**” position.

A reduced flowrate position identified by the “**LOW**” mark produces the preset minimum burner power.

Cleaning the heating plate :

**DO NOT USE WATER TO CLEAN THE HEATING
PLATE WHEN IT IS HOT.
This can damage it.**

Immediately remove any spillages to make cleaning easier. You can use commercially available special products for cleaning cast iron.

If the cast iron is heavily soiled, use scouring pads and grease after cleaning.



USER'S MANUAL VOUGEOT - VOLNAY

BEFORE USING OVENS

In order to achieve optimum use and maximum benefit from your oven, please read the following hints carefully in order to familiarise yourself with the principles of oven cooking.

An oven cooks and heats by using a heat source which is generally located inside the oven. This heat source heats the air and then the entire oven. The food therefore cooks thanks to the heat given off by the heating elements but also thanks to heat radiated from the oven walls.

This is why it is advisable to:

- Pre-heat the oven for 10 to 12 minutes depending on the setting selected before placing your dish in the oven.
- When placing the dish in the oven, make sure that it is not too close to the oven walls in order to prevent the edges of dishes being exposed to excessive radiated heat.



The material of which plates and moulds are made influences cooking due to its thickness, ability to transmit heat and its colour.

- Aluminium, earthenware and aluminium with a non-stick coating reduce cooking and underside browning. These materials are recommended for cooking cakes and roasts.
- Enamelled cast iron, anodised aluminium, tin-plated iron, ovenproof glass, heat-resistant porcelain and aluminium with a non-stick coating and coloured exterior increase underside browning. These materials are recommended in particular for open tarts, quiches and all crispy preparations that must be browned on the underside as well as on the top.

In order to prevent smoke being given off due to grease splashes when cooking meat, it is advisable to use pans that have high thermal inertia (earthenware or enamelled cast iron pans) **with high edges** of a size that matches the joint being roasted. Turn red meats over half way through cooking.

It is inadvisable to place a pan directly on the base of the oven or to cook joints simply placed in the drip tray. These few hints plus your own experience will enable you to achieve excellent results.

Danger :

-  When the oven or grill is switched on, accessible parts may become very hot. Keep children away from them. Be careful when handling dishes and shelves.
-  Openings or slits for ventilation or heat dissipation must not be blocked.
-  Never store flammable products in the compartment for saucepans



USER'S MANUAL VOUGEOT - VOLNAY

GAS OVEN

The gas oven is a high-performance oven. Some chefs are convinced that gas ovens do not dry out dishes during cooking. The results obtained are excellent and energy consumption is lower!

Gas ovens are ideal for slow cooking, for instance dishes cooked in earthenware dishes (terrines, gratins, ragouts, etc.) as well as for meats that require fast cooking and need to be sealed (loin of lamb) or even roasts which do not form an outside crust and remain really succulent.

In addition, gas ovens are ideal for cooking all dishes that require high "bottom heat" (1). We recommend the use of electric ovens for dishes that have to be cooked in a dry atmosphere or at very low temperatures (below 150 °C / 302 °F) such as meringues and certain cakes and pastries.

(1) "Bottom heat" is obtained through heat from the lower part of the oven, i.e. in the case of a gas oven, the location where the heat source is situated. Bottom heat is recommended for cooking fruit tarts, quiche lorraines, etc. for example.

Description :

Made of sheet steel with an acid-resistant enamel coating applied at 850 °C / 1562 °F; the gas ovens have racks with 4 shelf positions (58 mm / 2⁵/₁₆" spacing) allowing shelves and flatware to slide in easily. The oven volume is 62 litres / 2.18 ft³.

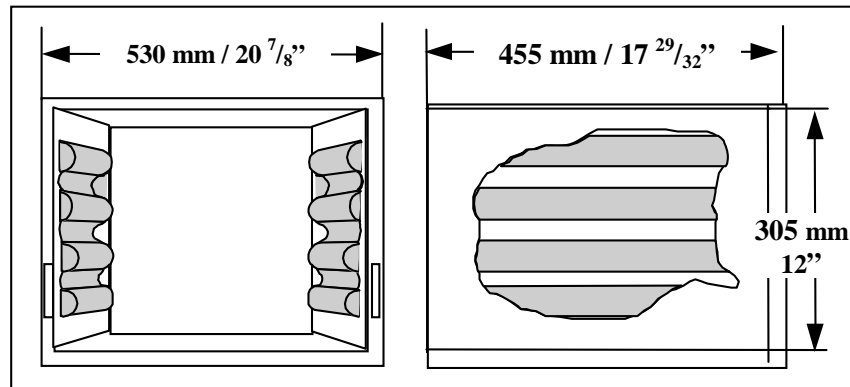

The gas oven is supplied equipped with a pastry tray, shelf and roasting pan as standard.

The oven burner is controlled by a thermostat valve. A thermocouple safety cut-out switches off the gas supply to the thermostat valve if the burner is accidentally extinguished.

The oven burner is a large unit in order to ensure even heating of the base surface area. Its thermal output is 4.0 kW.



USER'S MANUAL

VOUGEOT - VOLNAY

Use the oven :

Turn the oven thermostat valve control knob counterclockwise past the "IGN" mark to the desired temperature. An audible clicking sound will be heard.

The clicking sound stops when the gas has been ignited on the pilot.

To turn off, turn the control knob clockwise to the **Off** position. The control knob returns to its initial position, the latching mechanism operates and the gas safety cut-out is activated.

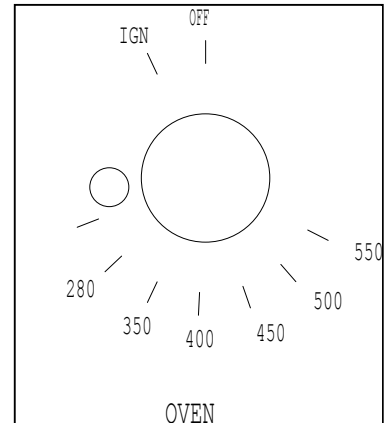

Before using the oven for the first time, it is advisable to switch it on without anything in it at the maximum thermostat position for 1/2 hour in order to eliminate the smell of fumes due to the composition of the mineral wool used to insulate the oven and residues from greases applied during manufacture. These odours will disappear after the oven has been used a few times.

Useful hints :

- Use pans with high edges for roasting in order to minimise grease splashes.
- When cooking fruit tarts, place the drip tray at the bottom of the oven in order to collect any spillages.

- It is also advisable never to place foodstuffs directly in the drip tray

To remove oven racks :

- Pull rack forward to the stop position.
- Raise the forward edge of the rack and lift out..
- Reverse procedure to install racks.

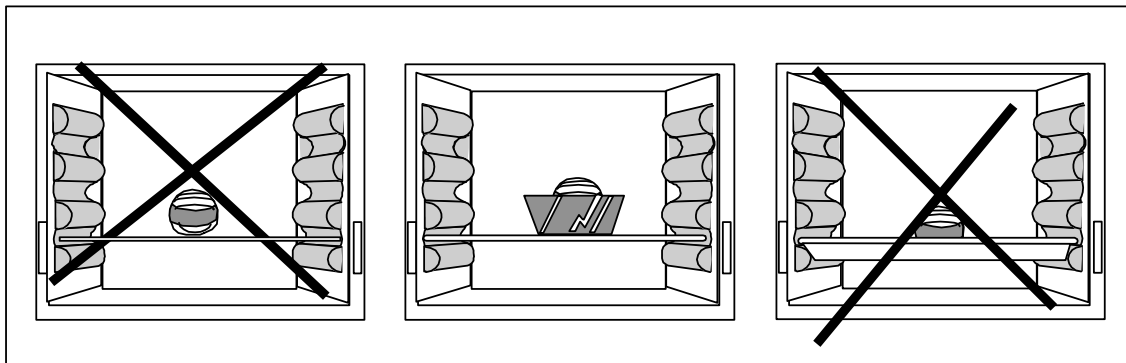



USER'S MANUAL VOUGEOT - VOLNAY

ELECTRIC OVEN

Electric ovens are simple to use and are ideal for cooking all usual dishes.

The electric oven has three heating elements and can be used as both an oven and a grill.

The electric oven is specially recommended for dry pastries such as almond biscuits, Genoese sponges, etc.

Description :

The dimensions of the oven are identical to those of the corresponding gas oven.

The electric oven is supplied equipped with a pastry tray, a shelf and a roasting pan as standard.

The heating elements consist of two 1030 W elements at the base and a peripheral 1300 W element in the roof which operate simultaneously.

In the grill position, only the central element of the 3100 W element in the roof operates.

The heating elements are controlled by a thermostat switch.

There are 3 indicator lamps on the control panel of the electric-oven version :

- Red signal lamp lights when the unit is energised (it remains lit unless the appliance is disconnected from the mains supply).
- Signal lamp **B** (red) lights when the components are switched on.
- Signal lamp **C** (orange) shows status of energised component. It is lit or not lit depending on the programmed temperature.





USER'S MANUAL

VOUGEOT - VOLNAY

Use :

The oven must be pre-heated at the thermostat setting chosen for cooking.

Turn the thermostat switch clockwise to the required mark. The red and orange indicator lamps (**B** and **C**) are lit. When the orange indicator lamp (**C**) is no longer lit, the selected temperature has been reached and you can then place your dish in the oven.

In order to switch off, turn the thermostat control knob from the right to the left as far as the **Off** position.

Prior to first use of oven: Preheat empty on thermostat setting 220°C for 20 minutes, then operate at maximum temperature for approximately 2 hours to heat the rockwool oven insulation and burn off the grease used in the manufacturing process. All odours will and smoke disappear when the oven has been used a few times.

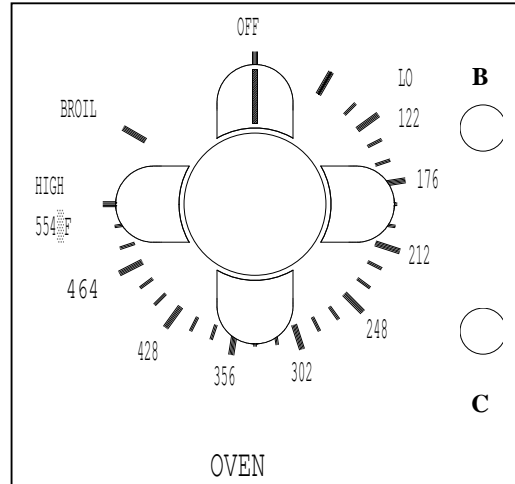

Useful hints :

- Use pans with high edges for roasting in order to minimise grease splashes.
- When cooking fruit tarts, place the drip tray at the bottom of the oven in order to collect any spillages.

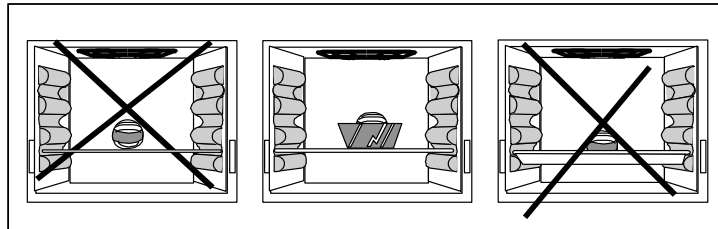

It is also advisable never to place foodstuffs directly in the drip tray

Electric grill :

The electric oven is equipped with a grid that can be used to grill meats and cook all types of dishes au gratin.

The electric grill is ideal to finish off crèmes brûlées or obtain perfect cooking of a rib of beef for example.

Use :

Turn the thermostat control knob to mark "**BROIL**".

In order to switch off, return the control knob to position **Off**.

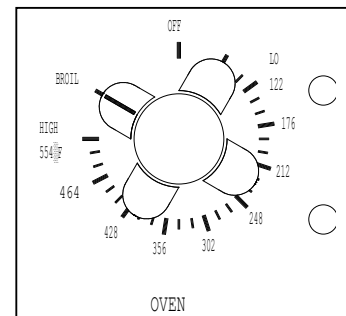

Useful hints :

CAUTION, the grill cooks very quickly, always keep an eye on the food you are cooking

- Lightly oil the surface of meat and fish before placing them on the sliding grid
- Only place and use the drip tray under the grid in order to collect cooking juices and prevent spillages in the case of food cooked au gratin.
- Increase the distance between the heating element of the grill and the food to be grilled depending on its thickness in order to avoid overcooking the outer surface without cooking the inside of the food.
- Keep a careful eye on the food you are cooking; grilling generally does not take long.

To remove oven racks :

- Pull rack forward to the stop position.
- Raise the forward edge of the rack and lift out.
- Reverse procedure to install racks.

When grilling, the door must be closed and only opened to inspect the foods and then close again.



USER'S MANUAL VOUGEOT - VOLNAY

ELECTRIC FORCED CONVECTION OVEN

The forced convection oven is a recent development in cooking techniques. Its principle is straightforward: air circulates over a heating element, is heated when it comes into contact with the element and the heat thus obtained in the oven is used to cook food.

Air circulation is achieved by using one or two turbines inside the oven which draw in air and expel it onto one or two heating elements, thus producing movement of warm air referred to as "convection".

Forced convection ovens have many advantages, the main benefit being that identical or different dishes can be cooked evenly at several levels. It is therefore particularly suitable for cooking cakes, pastries, Viennese bread or flaky pastry.

It heats quickly and defrosts frozen food evenly.

Different dishes can be cooked simultaneously without taste transference because odours are destroyed as the air passes over the heating element.

Description :

Made of sheet steel with an acid-resistant enamel coating applied at 850 ° C / 1562 °F, the 62 litres / 2.18 ft³ oven has racks with 4 shelf positions (58 mm / 2 ⁵/₁₆" spacing) allowing shelves and flatware to slide in easily.

The dimensions of the oven are identical to the gas oven apart from its depth which is 405 mm / 1' - 3 ⁵/₁₆".

The forced convection oven is equipped with one pastry tray, one shelf and one roasting pan as standard.

The oven is heated by two circular 1850 Watt elements which surround two reaction type fans.

This can optionally be fitted with an electric grill with a rating of 3100 W.

The heating element is controlled by a thermostat switch, the control panel has 3 indicator lamps :

- Red signal lamp lights when the unit is energised (it remains lit unless the appliance is disconnected from the mains supply).
- Signal lamp **B** (red) lights when the components are switched on.
- Signal lamp **C** (orange) shows status of energised component. It is lit or not lit depending on the programmed temperature.

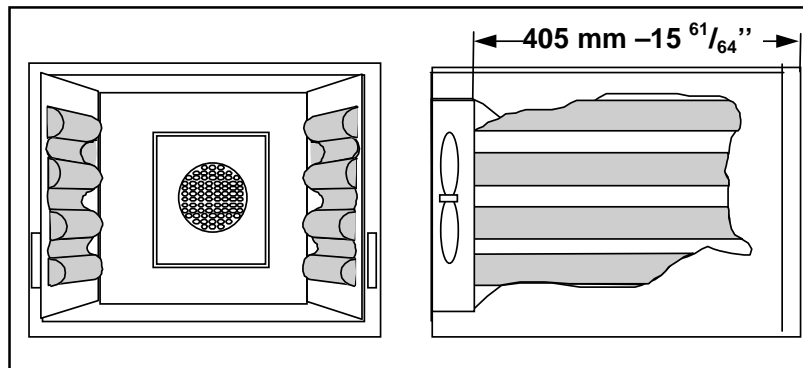



USER'S MANUAL

VOUGEOT - VOLNAY

Use :

The oven must be pre-heated at the thermostat setting chosen for cooking.

Turn the thermostat switch clockwise to the required mark. The red and orange indicator lamps (**B** and **C**) are lit. When the orange indicator lamp (**C**) is no longer lit, the selected temperature has been reached and you can then place your dish in the oven.

In order to switch off, turn the thermostat control knob from the right to the left as far as the **Off** position.

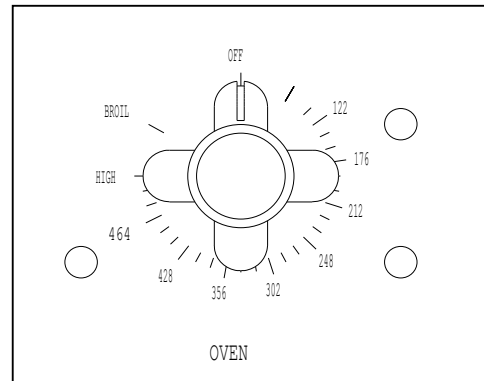

Before using the oven for the first time, it is advisable to switch it on without anything in it at the maximum thermostat position for 1/2 hour in order to eliminate the smell of fumes due to the composition of the mineral wool used to insulate the oven and residues from greases applied during manufacture. These odours will disappear after the oven has been used a few times.

Grill (option) :

Turn the control knob to the setting beyond the **BROIL** position. To switch off, turn the selector knob from right to left as far as the **Off** mark.

Note : While the grill is switched on, the fan continues to operate.

To remove oven racks :

- Pull rack forward to the stop position.
- Raise the forward edge of the rack and lift out.
- Reverse procedure to install racks.

Useful hints :

When cooking different dishes simultaneously, preferably place cakes and pastries at higher levels above other items to be cooked. If the cooking times of dishes vary, place them in the oven so that they are cooked just in time to serve them and remove them as soon as they are ready.

In a forced convection oven cooking can take place at temperatures lower than in a conventional oven. Consider reducing the heating temperature.

- Use pans with high edges for roasting in order to minimise grease splashes (e.g. casserole without lid).
- When cooking fruit tarts, place the drip tray at the bottom of the oven in order to collect any spillages.
- It is also advisable never to place foodstuffs directly in the drip tray.

CAUTION : The grill cooks very quickly and the user must always keep an eye on it.

When grilling, the door must be closed and only opened to inspect the foods and then close again.



USER'S MANUAL VOUGEOT - VOLNAY

HOT CUPBOARD

The plate warmer is used to keep dishes hot and allow greater flexibility when organising your meals. Its principle is straightforward and involves using a heating element to keep your plate warmer heated at the desired temperature.

Heating is obtained by means of a heating element located in the lower part under the base.

Description

Made of fully thermally-insulated stainless steel plate, the plate warmer has 5 levels that can accommodate standard catering sized shelves GN 1/1 (530 mm (20.8'') x 325 mm (12.8'')).

The plate warmer is equipped with two shelves as standard.

The plate warmer is heated by a 1030 W element.

The heating element is controlled by a thermostat switch on the front control panel.

An indicator lamp next to the control knob indicates thermostat control of the heating element. It is lit or no longer lit depending on the programme temperature.

Use

The plate warmer must be pre-heated roughly one hour before plates or dishes are placed inside it.

Turn the thermostat switch clockwise to the selected mark. The orange indicator lamp (A) is lit and goes out when the desired temperature has been reached and you can load the plate warmer.

In order to switch off, turn the thermostat control knob from the right to the left to position O.

Useful hints

Before using the plate warmer for the first time, it is advisable to switch it on without anything in it at the maximum thermostat position for 1/2 hour in order to eliminate the smell of fumes due to the composition of the mineral wool used to insulate the plate warmer and residues from greases applied during manufacture. These odours will disappear after the plate warmer has been used a few times.

- Never place plates directly on the base, crockery may break due to the rapid increase in temperature.

- Your dishes or plates may be extremely hot depending on the temperature selected. Take the necessary precautions before handling them.

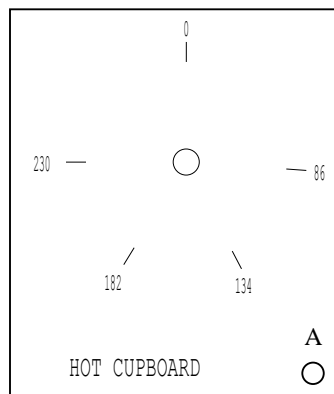



USER'S MANUAL VOUGEOT - VOLNAY

CLEANING

BEFORE ANY CLEANING WORK, CLOSE THE GAS SUPPLY AND/OR ISOLATE FROM THE MAIN ELECTRICAL SUPPLY

Stainless Steel

- All stainless steel parts should be cleaned regularly with hot, soapy water or any other neutral, non-abrasive detergent at the end of each cooling period.
- Wipe up any spills immediately.
- When soapy water will not do the job, special-purpose products made just for stainless steel can be purchased at your local hardware store or kitchen store.
- Do not use steel wool pads, abrasive cloths, abrasive cleaners or powders to clean. Do not use a metal knife, spatula, or any other metal tool to scrape stainless steel. Scratches are almost impossible to remove.
- Do not permit citrus or tomato juice or forms of brine (concentrations of salt, sauerkraut, etc.) to remain on the stainless steel surface, as citric acid or anything acidic will cause corrosion (pitting) and permanently discolor stainless steel.

Caution: Do NOT use any chlorinated cleansers (bleach of any kind) or ammonia to clean the stainless steel, as it will permanently discolor stainless steel.

Oven

Do not use abrasive cleaners on the oven walls. Special oven cleaning products may be used but should be kept away from the electrical elements, thermal probes, rubber gasket/seals, and hinges. You may remove the oven door gasket when using any oven cleaning products.

Be sure to remove all residues from surfaces after using any cleaning products.

Clean the rear cover(s) (electric oven or fan-assisted oven) to ensure that the cooling louvers are not blocked with deposits.

After cleaning, before use, make sure that the base is properly mounted at rear and slid forward and fitted under the front edge of the oven in order to avoid deformation of the base due to heat. (The bottom base enamel panel has a slight torsional twist designed into it and will not lay flat when loose or removed – this is on purpose – it will be in compression when fitted properly).

Enameled Surfaces

Use a sponge soaked in soapy water or a degreasing product applied with a soft cloth.

Never use any abrasives and avoid excessive or harsh rubbing when cleaning which can leave permanent marks on the enamel.

Caution: Do NOT allow any metal, cast iron, or brass polish/cleaners (Brasso, Copper Brite, Flitz, etc.) to come in contact with any enameled surfaces. The chemicals will cause permanent damage to the enameled finish.



USER'S MANUAL VOUGEOT - VOLNAY

CAST IRON CLEANING

Heating Plates

Caution: Do Not Use Water To Clean The Heating Plate When It Is Hot.
This can damage it.

** These are considered work surfaces and not recommended for direct food contact **

- **Traditional Simmer Plate “Coup de Feux” (CF)** (with removable plug)
- **Large Portable Simmer Plate “Plaque Centrale Grand Mijotage” (PCFC)** (solid surface)

Useful hint: “Seasoning” the heating plate before using it and keeping it “seasoned” will protect it against oxidation (rust). “Seasoning” is just using a paper towel/cloth and coating the cast iron with high-temperature oil/fat (**coconut oil**) when it is warm and letting it dry.

After each use, and while the plate is still warm, clean it off with a cleaning pad (Scotch Brite, for example) and a damp cloth. Use of steel wool is not recommended because if there is any metal residue left behind it will promote oxidation. Removing spills immediately will make cleaning easier. Drying the surface after cleaning and keeping the surface free of moisture will prevent oxidation (rust).

If the cast iron is heavily soiled, use a non-metallic scouring pad or stiff bristle nylon brush to clean. After any heavy cleaning it is recommended that you “season” the grill again (as you did before you used it the first time) to replace the high-temperature oil/fat and prevent oxidation. If you ever need to remove heavy oxidation, rust or other marks you can sand the surface with an emery cloth.

- **Mijotage/Simmer Plate (PM)** (Portable Cast Iron Plate w/ holes over burners)

Using a brush or cleaning pad, wash with soap and water and then dry.

Grates

Using a brush or cleaning pad, wash with soap and water and then dry.

Grill Plate (with ridges)/Griddle Plate (smooth)– (Cast Iron Plate with treated finish)

Using a brush or cleaning pad, wash with soap and water and then dry. Even though these plates have a treated finish, a light “seasoning” of these cooking surfaces will make for easier cleaning but it is not required.



USER'S MANUAL

VOUGEOT - VOLNAY

Brass

Newly machined brass parts will have a shine to them. However, these parts are a non-lacquered surface so as they age and are used, they will develop a patina. Some consider this to be a very classic look and are careful to maintain this discriminating look. If, on the other hand, you wish to have a polished look to your brass parts, and decide to use a cleaner/polish of any kind, DO NOT allow any cleaner/polish to come in contact with the enamel or stainless steel surfaces as it could permanently discolor the finish.

- Towel Bar Supports – Wash with soap and water and then dry with a soft cloth.
- Control Knobs and Drawer Pulls - Wash with soap and water and then dry with a soft cloth.

Chrome

Wash with soap and water and then dry with a soft cloth. DO NOT allow any cleanser/polish to come in contact with the enamel or stainless steel surfaces as it could permanently discolor the finish.

Burner Assembly (Two parts - Aluminum Burner Bowl and Brass Burner Caps)

The burners are made in two parts in order to facilitate cleaning. Clean them separately.

- Aluminum Burner Bowl - Using a non-metallic brush, wash with soap and water. (Older bowls, pre-1999, have small flame hole that MUST be kept clean and free of residue of any kind to allow for proper operation of the burner.)
- Brass Burner Caps - Using a non-metallic brush, wash with soap and water. The small holes MUST be kept clean and free of residue of any kind or the burner will not operate properly.

Please note: The brass burner caps come to you very shiny because this is how they look after the machining process. Even though the cosmetic look of the brass looks great, it is chosen for its machinability and durability. Once you start enjoying your range, it is normal to see the brass lose its new look and develop a brownish, mottled appearance. It is not recommended that you polish these caps as you could affect the performance and shorten the use.